



**Robert Bosch Power Tools GmbH**

70538 Stuttgart  
GERMANY

[www.bosch-pt.com](http://www.bosch-pt.com)

**1 609 92A 35T** (2016.10) PS / 11



1 609 92A 35T

# GBH Professional

2-18 E | 2-18 RE



cn 正本使用说明书



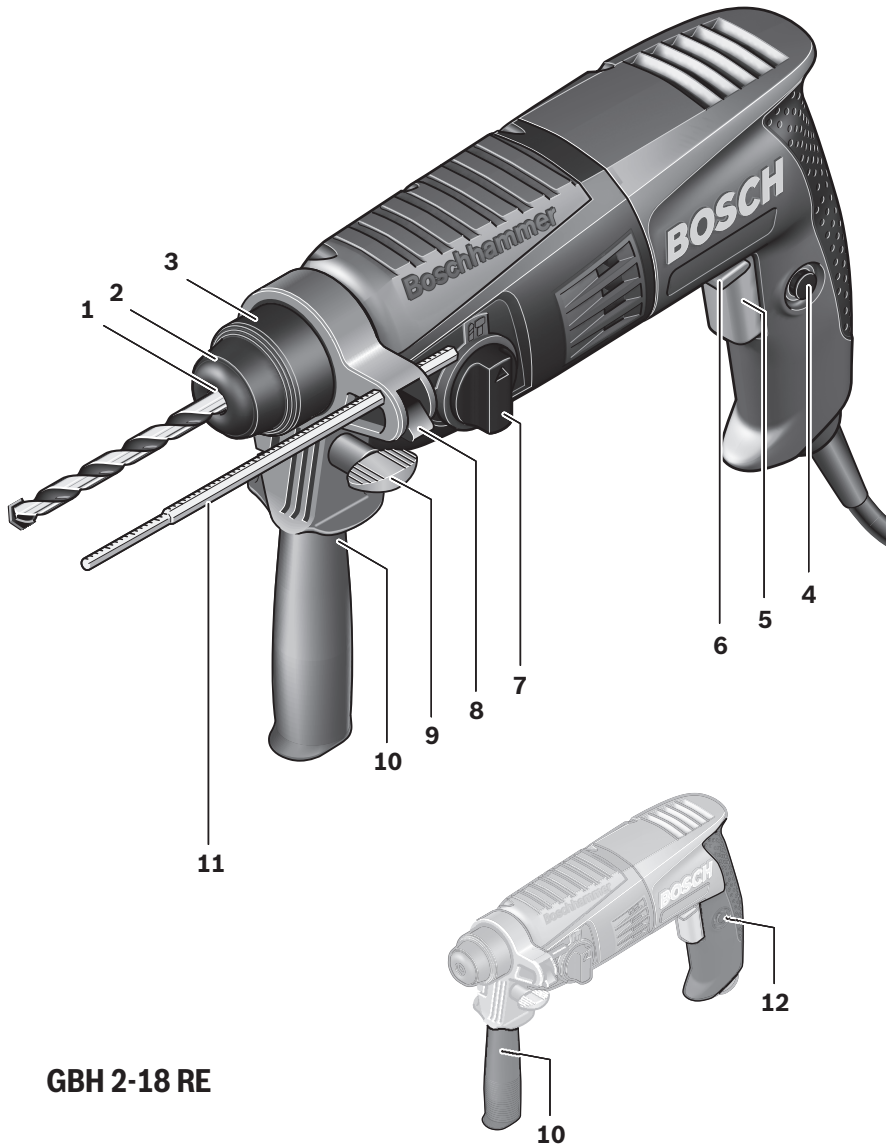

**GBH 2-18 RE**

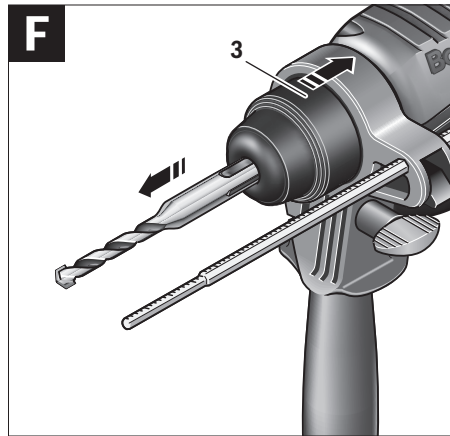
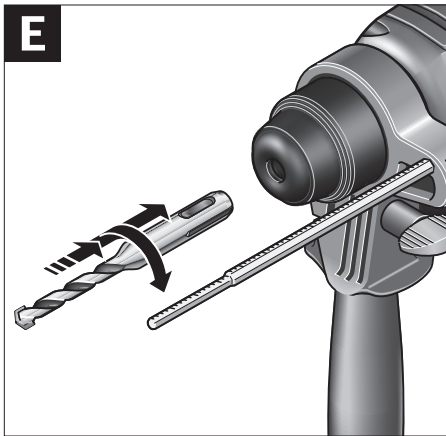
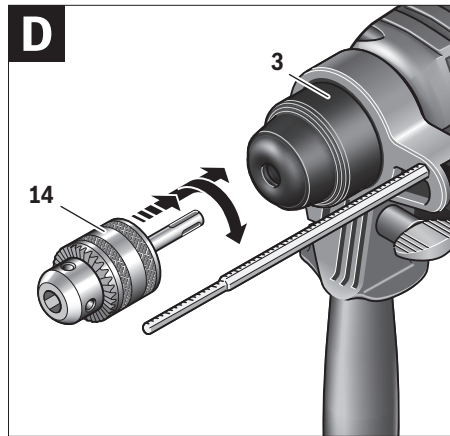
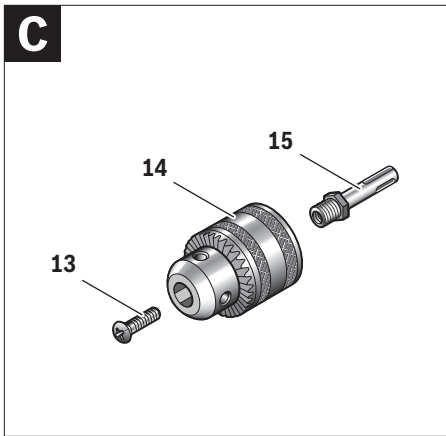
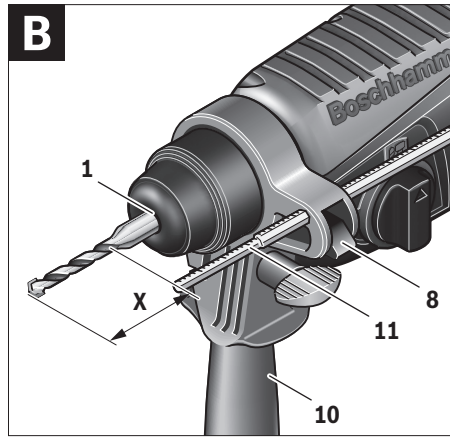
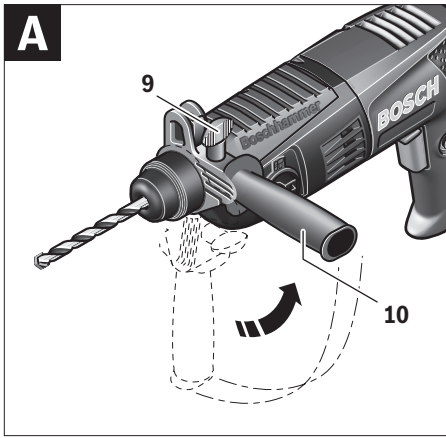

4 |

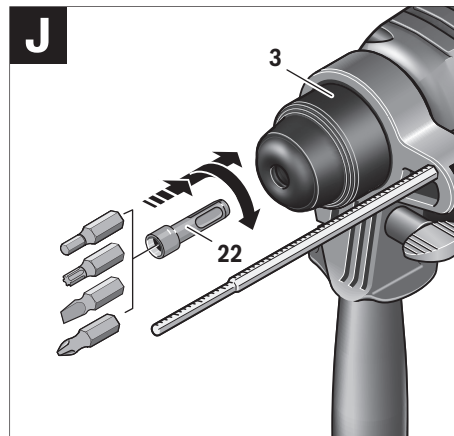
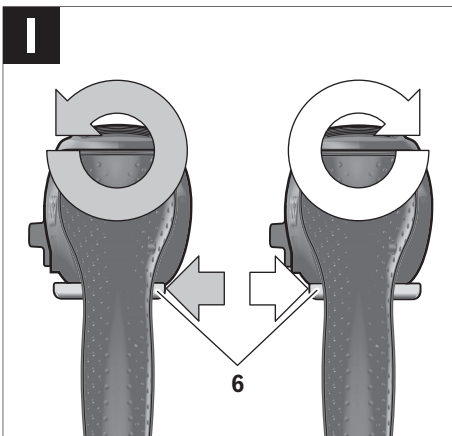
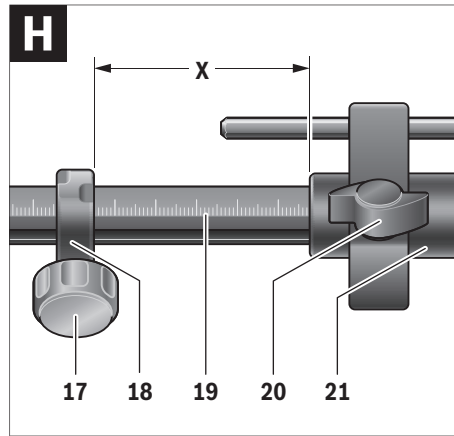
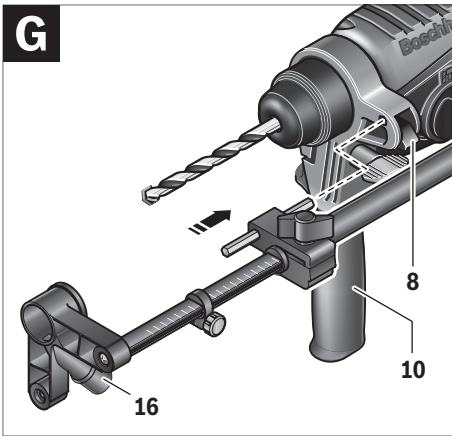

# 中文

## 安全规章

### 电动工具通用安全警告

**警告！** 阅读所有警告和所有说明！不遵照以下警告和说明会导致电击、着火和/或严重伤害。

保存所有警告和说明书以备查阅。

在所有下列的警告中术语“电动工具”指市电驱动（有线）电动工具或电池驱动（无线）电动工具。

#### 工作场地的安全

- ▶ 保持工作场地清洁和明亮。混乱和黑暗的场地会引发事故。
- ▶ 不要在易爆环境，如有易燃液体、气体或粉尘的环境下操作电动工具。电动工具产生的火花会点燃粉尘或气体。
- ▶ 让儿童和旁观者离开后操作电动工具。注意力不集中会使操作者失去对工具的控制。

#### 电气安全

- ▶ 电动工具插头必须与插座相配。绝不能以任何方式改装插头。需接地的电动工具不能使用任何转换插头。未经改装的插头和相配的插座将减少电击危险。
- ▶ 避免人体接触接地表面，如管道、散热片和冰箱。如果你身体接地会增加电击危险。
- ▶ 不得将电动工具暴露在雨中或潮湿环境中。水进入电动工具将增加电击危险。
- ▶ 不得滥用电线。绝不能用电线搬运、拉动电动工具或拔出其插头。使电线远离热源、油、锐边或运动部件。受损或缠绕的软线会增加电击危险。
- ▶ 当在户外使用电动工具时，使用适合户外使用的外接软线。适合户外使用的软线将减少电击危险。
- ▶ 如果在潮湿环境下操作电动工具是不可避免的，应使用剩余电流动作保护器（RCD）。使用 RCD 可减小电击危险。

#### 人身安全

- ▶ 保持警觉，当操作电动工具时关注所从事的操作并保持清醒。当你感到疲倦，或在有药物、酒精或治疗反应时，不要操作电动工具。在操作电动工具时瞬间的疏忽会导致严重人身伤害。
- ▶ 使用个人防护装置。始终佩戴护目镜。安全装置，诸如适当条件下使用防尘面具、防滑安全鞋、安全帽、听力防护等装置能减少人身伤害。
- ▶ 防止意外起动。确保开关在连接电源和/或电池盒、拿起或搬运工具时处于关断位置。手指放在已

接通电源的开关上或开关处于接通时插入插头可能会导致危险。

- ▶ 在电动工具接通之前，拿掉所有调节钥匙或扳手。遗留在电动工具旋转零件上的扳手或钥匙会导致人身伤害。
- ▶ 手不要伸展得太长。时刻注意立足点和身体平衡。这样在意外情况下能很好地控制电动工具。
- ▶ 着装适当。不要穿宽松衣服或佩戴饰品。让衣服、手套和头发远离运动部件。宽松衣服、佩饰或长发可能会卷入运动部件中。
- ▶ 如果提供了与排屑、集尘设备连接用的装置，要确保他们连接完好且使用得当。使用这些装置可减少尘屑引起的危险。

#### 电动工具使用和注意事项

- ▶ 不要滥用电动工具，根据用途使用适当的电动工具。选用适当设计的电动工具会使你工作更有效、更安全。
- ▶ 如果开关不能接通或关断工具电源，则不能使用该电动工具。不能用开关来控制的电动工具是危险的且必须进行修理。
- ▶ 在进行任何调节、更换附件或贮存电动工具之前，必须从电源上拔掉插头和/或使电池盒与工具脱离。这种防护性措施将减少工具意外起动的危险。
- ▶ 将闲置不用的电动工具贮存在儿童所及范围之外，并且不要让不熟悉电动工具或对这些说明不了解的人操作电动工具。电动工具在未经培训的用户手中是危险的。
- ▶ 保养电动工具。检查运动件是否调整到位或卡住，检查零件破损情况和影响电动工具运行的其他状况。如有损坏，电动工具应在使用前修理好。许多事故由维护不良的电动工具引发。
- ▶ 保持切削刀具锋利和清洁。保养良好的有锋利切削刃的刀具不易卡住而且容易控制。
- ▶ 按照使用说明书，考虑作业条件和进行的作业来使用电动工具、附件和工具的刀头等。将电动工具用于那些与其用途不符的操作可能会导致危险。

#### 维修

- ▶ 将你的电动工具送交专业维修人员，使用同样的备件进行修理。这样将确保所维修的电动工具的安全性。

#### 锤类工具的安全警告

- ▶ 戴好耳罩。暴露在噪声中会引起听力损伤。
- ▶ 使用随工具提供的辅助手柄。操作失手会引起人身伤害。
- ▶ 在切削附件可能触及暗线或其自身软线之处进行操作时，要通过绝缘握持面来握持工具。切削附件碰到带电导线会使工具外露的金属零件带电从而使操作者受到电击。

## 6 | 中文

- ▶ **使用合适的侦测装置侦察隐藏的电线，或者向当地的相关单位寻求支援。** 接触电线可能引起火灾并让操作者触电。损坏了瓦斯管会引起爆炸。凿穿水管不仅会造成严重的财物损失，也可能导致触电。
- ▶ **工作时必须用双手握紧电动工具，并且要确保立足稳固。** 使用双手比较能够握稳电动工具。
- ▶ **固定好工件。** 使用固定装置或老虎钳固定工件，会比用手持握工件更牢固。
- ▶ **等待电动工具完全静止后才能够放下机器。** 机器上的工具可能在工作中被夹住，而令您无法控制电动工具。

## 产品和功率描述



阅读所有的警告提示和指示。如未确实遵循警告提示和指示，可能导致电击，火灾并且 / 或其他的严重伤害。

### 按照规定使用机器

本电动工具适合在混凝土，砖墙和石材上进行震动钻。另外也可以使用本电动工具在木材，金属，陶材和塑料上进行无震动功能的正常钻。有电子调节装置和正反转功能的电动工具也能够拧转螺丝。

### 插图上的机件

机件的编号和电动工具详解图上的编号一致。

- 1 SDS-plus (四坑系统) 工具接头

### 技术数据

锤钻		GBH 2-18 E	GBH 2-18 RE
物品代码		3 611 B58 2..	3 611 B58 3..
转速控制装置		●	●
正 / 反转功能		-	●
额定输入功率	瓦	550	550
额定转速下的冲击次数	次 / 分	1150 - 3960	1150 - 3960
单一冲击强度符合 EPTA-Procedure 05/2009 的规定	焦耳	1.7	1.7
标称转速			
- 正转	次 / 分	450 - 1550	450 - 1550
- 反转	次 / 分	-	450 - 930
工具夹头		SDS-plus (四坑系统)	SDS-plus (四坑系统)
主轴颈直径	毫米	43 (欧洲标准)	43 (欧洲标准)
最大钻孔直径:			
- 混凝土	毫米	18	18
- 钢	毫米	13	13
- 木材	毫米	30	30
重量符合 EPTA-Procedure 01:2014	公斤	2.0	2.0
绝缘等级		□ / II	□ / II

本说明书提供的参数是以 230 V 为依据，于低电压地区，此数据有可能不同。

- 2 防尘盖
- 3 锁定套筒
- 4 起停开关的锁紧键
- 5 起停开关
- 6 正反转开关 (GBH 2-18 RE)
- 7 "正常钻 / 震动钻" 的转换开关
- 8 调整深度尺的按键
- 9 调整辅助手柄的蝶翼螺丝
- 10 辅助手柄 (绝缘握柄)
- 11 深度尺
- 12 手柄 (绝缘握柄)
- 13 齿环夹头上的固定螺丝\*
- 14 齿环夹头\*
- 15 夹头的 SDS-plus (四坑系统) 接头柄\*
- 16 吸尘装备 (Saugfix) 的吸孔\*
- 17 吸尘装备 (Saugfix) 的拧紧螺丝\*
- 18 吸尘装备 (Saugfix) 的深度挡块\*
- 19 吸尘装备 (Saugfix) 的伸缩尺\*
- 20 吸尘装备 (Saugfix) 的蝶翼螺丝\*
- 21 吸尘装备 (Saugfix) 的导管\*
- 22 有 SDS-plus (四坑系统) 接头柄的通用连杆\*

\* 图表或说明上提到的附件，并不包含在基本的供货范围中。本公司的附件清单中有完整的附件供应项目。

## 安装

- ▶ **维修电动工具或换装零、配件之前，务必从插座上拔出插头。**

### 辅助手柄

- ▶ **操作电动工具时必须使用辅助手柄 10。**

#### 转动辅助手柄（参考插图 A）

您可以根据需要改变辅助手柄 10 的位置，以提高工作安全和增加工作的舒适性。

- 朝着逆时针的方向拧转调整辅助手柄的蝶翼螺丝 9，把辅助手柄 10 摆动到需要的位置上，接著再顺着时钟的转向拧紧调整辅助手柄的蝶翼螺丝 9。

#### 调整钻深（参考插图 B）

使用深度尺 11 可以设定需要的钻深 X。

- 按下调整深度尺的按键 8，再把深度尺装入辅助手柄 10 中。  
深度尺 11 上的肋纹必须朝下。
- 把 SDS-plus（四坑系统）工具插入 SDS-plus（四坑系统）接头 1 中，并把工具推到底。如果未安装好工具，会影响设定深度的准确性。
- 适当调整深度尺，从钻咀尖端到深度尺尖端的距离必须和需要的钻深 X 一致。

### 选择夹头和工具

进行震动钻时必须使用能够安装在 SDS-plus（四坑）夹头上的 SDS-plus（四坑）工具。

在木材，金属，陶材和塑料上进行无震动功能的正常钻，以及拧转螺丝时，必须使用无 SDS-plus 的工具（例如带圆柱柄的钻头）。上述工具必须配合快速夹头或齿环夹头一起使用。

### 更换齿环夹头

必须在机器上安装合适的夹头（齿环夹头，快速夹头或附件）后，才能使用无 SDS-plus（四坑系统）的工具（例如有圆柱柄的钻头）。

#### 组合齿环夹头（参考插图 C）

- 把有 SDS-plus（四坑系统）接头柄的通用连杆 15 转入齿环夹头 14 中。以螺丝 13 固定齿环夹头 14。**注意，固定螺丝有左螺纹。**

#### 安装齿环夹头（参考插图 D）

- 清洁接头柄的末端并在接头柄末端涂抹少许油脂。
- 把齿环夹头的接头柄拧入机器的工具接头中，至接头柄自动锁定为止。
- 抽拉齿环夹头，以确定夹头是否已经锁定了。

#### 拆卸齿环夹头

- 向后抽拉锁定套筒 3，接著便可以拔出齿环夹头 14。

### 更换工具

防尘盖 2 可以防止工作时凿削废尘侵入夹头中。安装工具时必须小心，勿损坏防尘盖 2。

- ▶ **如果防尘盖损坏了必须马上更换。最好委托本公司的顾客服务处换装。**

#### 安装 SDS-plus（四坑系统）工具（参考插图 E）

有了 SDS-plus（四坑系统）夹头，不必使用工具也可以快速便利地安装钻头。

- 清洁工具柄並在柄上塗少许潤滑脂。
- 把工具转入工具夹头中，至工具自动锁牢为止。
- 抽拉工具以确定它是否正确锁紧了。

SDS-plus（四坑系统）系统的工具是活动的，因此在无负载状态下此类工具会偏心旋转。开始钻孔时工具便会自动定心，所以上述现象并不会影响钻孔的准确度。

#### 拆卸 SDS-plus（四坑系统）工具（参考插图 F）

- 向后推移锁定套筒 3 並取出工具。

#### 安装无 SDS-plus（四坑系统）的工具

**指示：**不可以使用无 SDS-plus（四坑系统）的工具进行震动钻！无 SDS-plus（四坑系统）的工具和它的夹头会在进行震动钻时受损。

- 装上齿环夹头 14（参考“更换齿环夹头”，第 7 页）。
- 转动齿环夹头 14 至能够装入工具为止，安装好工具。
- 把夹头扳手插入齿环夹头 14 上的扳手孔中，均匀地拧紧扳手来固定好工具。
- 把转换开关 7 拧转到“正常钻”的符号上。

#### 拆卸无 SDS-plus（四坑系统）的工具

- 使用夹头扳手，朝著逆时针方向转动齿环夹头 14 上的套筒，至能够拿出工具为止。

### 使用吸尘装备（Saugfix）吸尘（附件）

- ▶ 含铅的颜料以及某些木材、矿物和金属的加工废尘有害健康。机器操作者或者工地附近的人如果接触、吸入这些废尘，可能会有过敏反应或者感染呼吸道疾病。

某些尘埃（例如加工橡木或山毛榉的废尘）可能致癌，特别是和处理木材的添加剂（例如木材的防腐剂等）结合之后。只有经过专业训练的人才能够加工含石棉的物料。

- 尽可能使用适合物料的吸尘装置。
- 工作场所要保持空气流通。
- 最好佩戴 P2 滤网等级的口罩。

请留心并遵守贵国和加工物料有关的法规。

- ▶ **避免让工作场所堆积过多的尘垢。尘埃容易被点燃。**

## 8 | 中文

**安装吸尘装备 (Saugfix) (参考插图 G)**

吸尘装备 Saugfix (附件) 是用来吸取钻孔时产生的废屑。当钻头吃入工件中时吸尘装备会向后回缩, 这样可以确保吸尘装备能够紧贴着工件表面。

- 按住辅助手柄上的按键 **8**, 拔出深度尺 **11**。再度按下按键 **8**, 把吸尘装备从机器前端插入辅助把手 **10** 中。
- 在吸尘装备的吸孔 **16** 上安装吸尘软管 (管直径 19 毫米, 附件)。

根据工件的物料选择合适的吸尘装置。

吸尘可能危害健康, 可能导致癌症或干燥的废屑时, 务必使用特殊的吸尘装置。

**在吸尘装备上设定钻孔深度 (参考插图 H)**

安装了吸尘装备后也能够设定钻孔深度 X。

- 把 SDS-plus (四坑系统) 工具插入 SDS-plus (四坑系统) 接头 **1** 中, 并把工具推到底。如果未安装好工具, 会影响设定深度的准确性。
- 松开吸尘装备上的蝶翼螺丝 **20**。
- 把尚未开动的电动工具紧紧地顶在工件上。SDS-plus (四坑系统) - 工具也必须紧贴着工件。
- 推移吸尘装备的导管 **21**, 让装备的顶端能够靠在钻孔表面上。不可以过度推出导管 **21**, 这样可能遮盖了伸缩尺 **19** 上的刻度。尽可能充分利用伸缩尺 **19** 上的刻度。
- 收紧蝶翼螺丝 **20**。放松吸尘装备上深度挡块的拧紧螺丝 **17**。
- 调整伸缩尺 **19** 上的深度挡块 **18** 的位置以设定钻深。插图中的线段长度 X 便是实际需要的钻孔深度。
- 拧紧螺丝 **17** 把挡块固定在这个位置。

**操作****操作机器**

- ▶ **注意电源的电压!** 电源的电压必须和电动工具铭牌上标示的电压一致。

**设定操作模式**

使用“正常钻/震动钻”的转换开关 **7**, 可以变换电动工具的操作方式。

**指示:** 务必先关闭电动工具, 然后才可以改变操作功能! 否则损坏电动工具。

- 转换操作功能时必须把“正常钻/震动钻”开关 **7**, 拧转到需要的开关位置上。

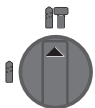

在混凝土或石材上进行**震动钻**时的设定方式

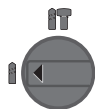

在木材, 金属, 陶材和塑料上进行**无震动**功能的**正常钻**以及**拧转螺丝**时的设定位置

**改变转向 (GBH 2-18 RE) (参考插图 I)**

使用正逆转开关 **6** 可以改变机器的转向。如果按住了起停开关 **5**, 则无法改变转向。

🔄 **正转:** 把正逆转开关 **6** 向右推到底。

🔄 **逆转:** 把正逆转开关 **6** 向左推到底。

进行震动钻和正常钻时, 必须把转向设定为正转。

**开动/关闭**

- 按下起停开关 **5**, 可以**开动**电动工具。
- **锁定**起停开关, 按住起停开关并同时按下锁紧键 **4**。
- **关闭**电动工具, 放开起停开关 **5**。如果起停开关 **5** 被锁定了, 先按下起停开关紧接着再放开开关。

**调整转速/冲击次数**

随著在起停开关 **5** 上施压大小, 可以无级式地提高或降低转速/冲击次数。

轻按起停开关 **5**, 机器以低转速/冲击次数运作。增强施加在起停开关上的压力, 可以提高机器的转速/冲击次数。

**过载离合器**

- ▶ **如果工具卡住了, 传往主轴的动力会中断。此时会产生非常大的震动力。因此操作机器时务必要用双手握紧机器, 并且要确保立足稳固。**
- ▶ **如果电动工具卡住了, 先关闭电动工具, 再取出工具。开动工具被卡住的电动工具, 会产生很高的反应力矩。**

**有关操作方式的指点**

- ▶ **维修电动工具或换装零、配件之前, 务必从插座上拔出插头。**

**安装螺丝批嘴 (参考插图 J)**

▶ **先关闭电动工具, 然后再把工具放置在螺母/螺丝上。安装在接头上的工具如果仍继续转动, 容易从螺丝头上滑开。**

▶ **在切削附件可能触及暗线或其自身软线之处进行操作时, 要通过绝缘握持面来握持工具。切削附件碰到带电导线会使工具外露的金属零件带电从而使操作者受到电击。**

使用螺丝批嘴时必须安装在机器上安装有 SDS-plus (四坑系统) 接头柄的通用连杆 **22**。

- 清洁接头柄的末端并在接头柄末端涂抹少许油脂。
- 把通用连杆拧入工具接头中, 并让连杆自动锁定。
- 抽拉连杆, 检查连杆是否已经正确锁牢。



- 把螺丝批嘴插入通用连杆中。必须使用与螺丝头大小相符的螺丝批嘴。
- 拆卸通用连杆时必须先向后抽拉锁定套筒 **3**，接着便可以工具接头上取出通用连杆 **22**。

## 维修和服务

### 维修和清洁

- ▶ **维修电动工具或换装零、配件之前，务必从插座上拔出插头。**
- ▶ **电动工具和通风间隙都必须保持清洁，这样才能提高工作品质和安全性。**
- ▶ **如果防尘盖损坏了必须马上更换。最好委托本公司的顾客服务处换装。**
- 每次操作完毕后，都得清洁工具接头 **1**。

如果必须更换连接线，务必把这项工作交给博世或者经授权的博世电动工具顾客服务执行，以避免危害机器的安全性能。

### 顾客服务处和顾客咨询中心

本公司顾客服务处负责回答有关本公司产品的修理、维护和备件的问题。以下的网页中有爆炸图和备件的资料：

**www.bosch-pt.com**

博世顾客咨询团队非常乐意为您解答有关本公司产品及附件的问题。

如需查询和订购备件，请务必提供产品型号铭牌上的10位数货号。

有关保证，维修或更换零件事宜，请向合格的经销商查询。

#### 中国大陆

博世电动工具（中国）有限公司

中国 浙江省 杭州市

滨江区滨康路 567 号

邮政编码：310052

免费服务热线：4008268484

传真：(0571) 87774502

电邮：contact\_ptcn@cn.bosch.com

www.bosch-pt.com.cn

罗伯特·博世有限公司

香港北角英皇道 625 号 21 楼

客户服务热线：+852 2101 0235

传真：+852 2590 9762

电邮：info@hk.bosch.com

网站：www.bosch-pt.com.hk

#### 制造商地址：

Robert Bosch Power Tools GmbH

罗伯特·博世电动工具有限公司

70538 Stuttgart / GERMANY

70538 斯图加特 / 德国

### 处理废弃物

必须以符合环保的方式，回收再利用损坏的机器、附件和废弃的包装材料。

不可以把电动工具丢入家庭垃圾中！

保留修改权。

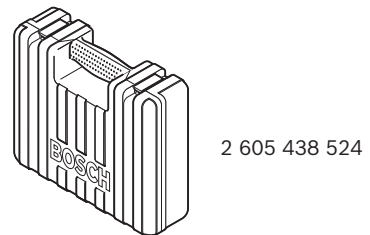
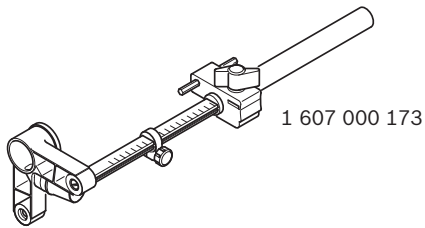
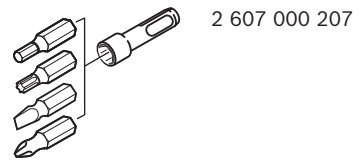
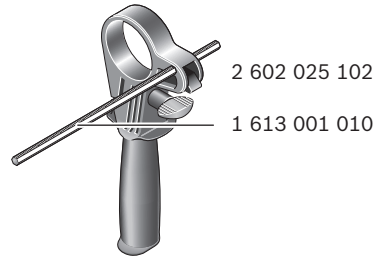
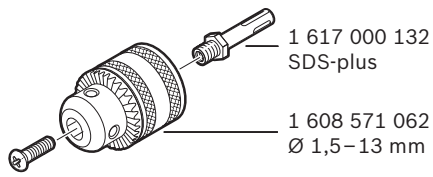

**以下各页勿打印！**

***Following pages  
are NOT for printing!***

## English

### Safety Notes

#### General Power Tool Safety Warnings

**⚠ WARNING** Read all safety warnings and all instructions. Failure to follow the warnings and instructions may result in electric shock, fire and/or serious injury.

#### Save all warnings and instructions for future reference.

The term "power tool" in the warnings refers to your mains-operated (corded) power tool or battery-operated (cordless) power tool.

#### Work area safety

- ▶ **Keep work area clean and well lit.** Cluttered or dark areas invite accidents.
- ▶ **Do not operate power tools in explosive atmospheres, such as in the presence of flammable liquids, gases or dust.** Power tools create sparks which may ignite the dust or fumes.
- ▶ **Keep children and bystanders away while operating a power tool.** Distractions can cause you to lose control.

#### Electrical safety

- ▶ **Power tool plugs must match the outlet. Never modify the plug in any way. Do not use any adapter plugs with earthed (grounded) power tools.** Unmodified plugs and matching outlets will reduce risk of electric shock.
- ▶ **Avoid body contact with earthed or grounded surfaces, such as pipes, radiators, ranges and refrigerators.** There is an increased risk of electric shock if your body is earthed or grounded.
- ▶ **Do not expose power tools to rain or wet conditions.** Water entering a power tool will increase the risk of electric shock.
- ▶ **Do not abuse the cord. Never use the cord for carrying, pulling or unplugging the power tool. Keep cord away from heat, oil, sharp edges and moving parts.** Damaged or entangled cords increase the risk of electric shock.
- ▶ **When operating a power tool outdoors, use an extension cord suitable for outdoor use.** Use of a cord suitable for outdoor use reduces the risk of electric shock.
- ▶ **If operating a power tool in a damp location is unavoidable, use a residual current device (RCD) protected supply.** Use of an RCD reduces the risk of electric shock.

#### Personal safety

- ▶ **Stay alert, watch what you are doing and use common sense when operating a power tool. Do not use a power tool while you are tired or under the influence of drugs, alcohol or medication.** A moment of inattention while operating power tools may result in serious personal injury.
- ▶ **Use personal protective equipment. Always wear eye protection.** Protective equipment such as dust mask, non-skid safety shoes, hard hat, or hearing protection

used for appropriate conditions will reduce personal injuries.

- ▶ **Prevent unintentional starting. Ensure the switch is in the off-position before connecting to power source and/or battery pack, picking up or carrying the tool.** Carrying power tools with your finger on the switch or energising power tools that have the switch on invites accidents.
- ▶ **Remove any adjusting key or wrench before turning the power tool on.** A wrench or a key left attached to a rotating part of the power tool may result in personal injury.
- ▶ **Do not overreach. Keep proper footing and balance at all times.** This enables better control of the power tool in unexpected situations.
- ▶ **Dress properly. Do not wear loose clothing or jewellery. Keep your hair, clothing and gloves away from moving parts.** Loose clothes, jewellery or long hair can be caught in moving parts.
- ▶ **If devices are provided for the connection of dust extraction and collection facilities, ensure these are connected and properly used.** Use of dust collection can reduce dust-related hazards.

#### Power tool use and care

- ▶ **Do not force the power tool. Use the correct power tool for your application.** The correct power tool will do the job better and safer at the rate for which it was designed.
- ▶ **Do not use the power tool if the switch does not turn it on and off.** Any power tool that cannot be controlled with the switch is dangerous and must be repaired.
- ▶ **Disconnect the plug from the power source and/or the battery pack from the power tool before making any adjustments, changing accessories, or storing power tools.** Such preventive safety measures reduce the risk of starting the power tool accidentally.
- ▶ **Store idle power tools out of the reach of children and do not allow persons unfamiliar with the power tool or these instructions to operate the power tool.** Power tools are dangerous in the hands of untrained users.
- ▶ **Maintain power tools. Check for misalignment or binding of moving parts, breakage of parts and any other condition that may affect the power tool's operation. If damaged, have the power tool repaired before use.** Many accidents are caused by poorly maintained power tools.
- ▶ **Keep cutting tools sharp and clean.** Properly maintained cutting tools with sharp cutting edges are less likely to bind and are easier to control.
- ▶ **Use the power tool, accessories and tool bits etc. in accordance with these instructions, taking into account the working conditions and the work to be performed.** Use of the power tool for operations different from those intended could result in a hazardous situation.

#### Service

- ▶ **Have your power tool serviced by a qualified repair person using only identical replacement parts.** This will ensure that the safety of the power tool is maintained.

## Hammer Safety Warnings

- ▶ **Wear ear protectors.** Exposure to noise can cause hearing loss.
- ▶ **Use auxiliary handle(s), if supplied with the tool.** Loss of control can cause personal injury.
- ▶ **Hold the tool by the insulated gripping surfaces when performing operations where the application tool or the screw could contact hidden wiring or its own power cord.** Contact with a "live" wire will also make exposed metal parts of the power tool "live" and shock the operator.
- ▶ **Use suitable detectors to determine if utility lines are hidden in the work area or call the local utility company for assistance.** Contact with electric lines can lead to fire and electric shock. Damaging a gas line can lead to explosion. Penetrating a water line causes property damage or may cause an electric shock.
- ▶ **When working with the machine, always hold it firmly with both hands and provide for a secure stance.** The power tool is guided more secure with both hands.
- ▶ **Secure the workpiece.** A workpiece clamped with clamping devices or in a vice is held more secure than by hand.
- ▶ **Always wait until the machine has come to a complete stop before placing it down.** The tool insert can jam and lead to loss of control over the power tool.
- ▶ **Products sold in GB only:** Your product is fitted with a BS 1363/A approved electric plug with internal fuse (ASTA approved to BS 1362).  
If the plug is not suitable for your socket outlets, it should be cut off and an appropriate plug fitted in its place by an authorised customer service agent. The replacement plug should have the same fuse rating as the original plug.  
The severed plug must be disposed of to avoid a possible shock hazard and should never be inserted into a mains socket elsewhere.
- ▶ **Products sold in AUS and NZ only:** Use a residual current device (RCD) with a rated residual current of 30 mA or less.

## Product Description and Specifications



**Read all safety warnings and all instructions.** Failure to follow the warnings and instructions may result in electric shock, fire and/or serious injury.

### Intended Use

The machine is intended for hammer drilling in concrete, brick and stone. It is also suitable for drilling without impact in wood, metal, ceramic and plastic. Machines with electronic control and right/left rotation are also suitable for screwdriving.

### Product Features

The numbering of the product features refers to the illustration of the machine on the graphics page.

- 1 SDS-plus tool holder
- 2 Dust protection cap
- 3 Locking sleeve
- 4 Lock-on button for On/Off switch
- 5 On/Off switch
- 6 Rotational direction switch (GBH 2-18 RE)
- 7 Selector switch for drilling/hammer drilling
- 8 Button for depth stop adjustment
- 9 Wing bolt for adjustment of auxiliary handle
- 10 Auxiliary handle (insulated gripping surface)
- 11 Depth stop
- 12 Handle (insulated gripping surface)
- 13 Securing screw for key type drill chuck\*
- 14 Key type drill chuck\*
- 15 SDS-plus adapter shank for drill chuck\*
- 16 Extraction sleeve of the dust extraction attachment\*
- 17 Clamping screw for the dust extraction attachment\*
- 18 Depth stop of the dust extraction attachment\*
- 19 Telescopic pipe of the dust extraction attachment\*
- 20 Wing bolt of the dust extraction attachment\*
- 21 Guide pipe of the dust extraction attachment\*
- 22 Universal bit holder with SDS-plus shank\*

\*Accessories shown or described are not part of the standard delivery scope of the product. A complete overview of accessories can be found in our accessories program.

## Technical Data

Rotary Hammer		GBH 2-18 E	GBH 2-18 RE
Article number		3 611 B58 2..	3 611 B58 3..
Speed control		●	●
Right/left rotation		-	●
Rated power input	W	550	550
Impact frequency at rated speed	min <sup>-1</sup>	1150 - 3960	1150 - 3960
Impact energy per stroke according to EPTA-Procedure 05/2009	J	1.7	1.7
The values given are valid for a nominal voltage [U] of 230 V. For different voltages and models for specific countries, these values can vary.			

## 14 | English

Rotary Hammer		GBH 2-18 E	GBH 2-18 RE
Rated speed			
– Right rotation	min <sup>-1</sup>	450 – 1550	450 – 1550
– Left rotation	min <sup>-1</sup>	–	450 – 930
Tool holder		SDS-plus	SDS-plus
Spindle collar diameter	mm	43 (Euro-Norm)	43 (Euro-Norm)
Drilling diameter, max.:			
– Concrete	mm	18	18
– Steel	mm	13	13
– Wood	mm	30	30
Weight according to EPTA-Procedure 01:2014	kg	2.0	2.0
Protection class		□ / II	□ / II

The values given are valid for a nominal voltage [U] of 230 V. For different voltages and models for specific countries, these values can vary.

## Assembly

- ▶ **Before any work on the machine itself, pull the mains plug.**

### Auxiliary Handle

- ▶ **Operate your machine only with the auxiliary handle 10.**

#### Changing the position of the auxiliary handle (see figure A)

The auxiliary handle 10 can be set to any position for a secure and low-fatigue working posture.

- Turn the wing bolt for adjustment of the auxiliary handle 9 in anticlockwise direction and set the auxiliary handle 10 to the required position. Then tighten the wing bolt 9 again in clockwise direction.

#### Adjusting the Drilling Depth (see figure B)

The required drilling depth X can be set with the depth stop 11.

- Press the button for the depth stop adjustment 8 and insert the depth stop into the auxiliary handle 10. The knurled surface of the depth stop 11 must face downward.
- Insert the SDS-plus drilling tool to the stop into the SDS-plus tool holder 1. Otherwise, the movability of the SDS-plus drilling tool can lead to incorrect adjustment of the drilling depth.
- Pull out the depth stop until the distance between the tip of the drill bit and the tip of the depth stop corresponds with the desired drilling depth X.

### Selecting Drill Chucks and Tools

For hammer drilling, SDS-plus tools are required that are inserted in the SDS-plus drill chuck.

For drilling without impact in wood, metal, ceramic and plastic as well as for screwdriving, tools without SDS-plus are used (e.g., drill bits with cylindrical shank). For these tools, a keyless chuck or a key type drill chuck are required.

### Changing the Key Type Drill Chuck

To work with tools without SDS-plus (e.g., drills with cylindrical shank), a suitable drill chuck must be mounted (key type drill chuck or keyless chuck, accessories).

#### Mounting the Key Type Drill Chuck (see figure C)

- Screw the SDS-plus adapter shank 15 into a key type drill chuck 14. Secure the key type drill chuck 14 with the securing screw 13. **Please observe that the securing screw has a left-hand thread.**

#### Inserting the Key Type Drill Chuck (see figure D)

- Clean the shank end of the adapter shank and apply a light coat of grease.
- Insert the key type drill chuck with the adapter shank into the tool holder with a turning motion until it automatically locks.
- Check the locking effect by pulling the key type drill chuck.

#### Removing the Key Type Drill Chuck

- Push the locking sleeve 3 toward the rear and pull out the key type drill chuck 14.

### Changing the Tool

The dust protection cap 2 largely prevents the entry of drilling dust into the tool holder during operation. When inserting the tool, take care that the dust protection cap 2 is not damaged.

- ▶ **A damaged dust protection cap should be changed immediately. We recommend having this carried out by an after-sales service.**

#### Inserting SDS-plus Drilling Tools (see figure E)

The SDS-plus drill chuck allows for simple and convenient changing of drilling tools without the use of additional tools.

- Clean and lightly grease the shank end of the tool.
- Insert the tool in a twisting manner into the tool holder until it latches itself.
- Check the latching by pulling the tool.

As a requirement of the system, the SDS-plus drilling tool can move freely. This causes a certain radial run-out at no-load, which has no effect on the accuracy of the drill hole, as the drill bit centres itself upon drilling.

**Removing SDS-plus Drilling Tools (see figure F)**

- Push back the locking sleeve **3** and remove the tool.

**Inserting Drilling Tools without SDS-plus**

**Note:** Do not use tools without SDS-plus for hammer drilling! Tools without SDS-plus and their drill chucks are damaged by hammer drilling.

- Insert a key type drill chuck **14** (see “Changing the Key Type Drill Chuck”, page 14).
- Open the key type drill chuck **14** by turning until the tool can be inserted. Insert the tool.
- Insert the chuck key into the corresponding holes of the key type drill chuck **14** and clamp the tool uniformly.
- Set the selector switch **7** to the “Drilling” symbol.

**Removing Drilling Tools without SDS-plus**

- Turn the sleeve of the key type drill chuck **14** with the drill chuck key in anticlockwise direction until the drilling tool can be removed.

**Dust Extraction with the Dust Extraction Attachment (Accessory)**

- ▶ Dust from materials such as lead-containing coatings, some wood types, minerals and metal can be harmful to one’s health. Touching or breathing-in the dust can cause allergic reactions and/or lead to respiratory infections of the user or bystanders. Certain dust, such as oak or beech dust, is considered carcinogenic, especially in connection with wood-treatment additives (chromate, wood preservative). Materials containing asbestos may only be worked by specialists.
  - As far as possible, use a dust extraction system suitable for the material.
  - Provide for good ventilation of the working place.
  - It is recommended to wear a P2 filter-class respirator.
 Observe the relevant regulations in your country for the materials to be worked.

- ▶ **Prevent dust accumulation at the workplace.** Dust can easily ignite.

**Mounting the Dust Extraction Attachment (see figure G)**

For dust extraction, the dust extraction attachment (accessory) is required. When drilling, the dust extraction attachment retracts so that the attachment head is always close to the surface at the drill hole.

- Press the button for depth stop adjustment **8** and remove the depth stop **11**. Press button **8** again and insert the dust extraction attachment into the auxiliary handle **10** from the front.
- Connect an extraction hose (diameter 19 mm, accessory) to the extraction sleeve **16** of the dust extraction attachment.

The vacuum cleaner must be suitable for the material being worked.

When vacuuming dry dust that is especially detrimental to health or carcinogenic, use a special vacuum cleaner.

**Adjusting the Drilling Depth on the Dust Extraction Attachment (see figure H)**

The required drilling depth **X** can also be adjusted when the dust extraction attachment is mounted.

- Insert the SDS-plus drilling tool to the stop into the SDS-plus tool holder **1**. Otherwise, the movability of the SDS-plus drilling tool can lead to incorrect adjustment of the drilling depth.
- Loosen the wing bolt **20** on the dust extraction attachment.
- Without switching the power tool on, apply it firmly to the drilling location. The SDS-plus drilling tool must face against the surface.
- Position the the guide pipe **21** of the dust extraction attachment in its holding fixture in such a manner that the head of the dust extraction attachment faces against the surface to be drilled. Do not slide the guide pipe **21** further over the telescopic pipe **19** of the dust extraction attachment than required, so that as much as possible of the scale **19** on the telescopic pipe remains visible.
- Retighten the wing bolt **20** again. Loosen the clamping screw **17** on the depth stop of the dust extraction attachment.
- Move the depth stop **18** on the telescopic pipe **19** in such a manner that the clearance **X** shown in the figure corresponds with the required drilling depth.
- Tighten the clamping screw **17** in this position.

**Operation****Starting Operation**

- ▶ **Observe correct mains voltage! The voltage of the power source must agree with the voltage specified on the nameplate of the machine. Power tools marked with 230 V can also be operated with 220 V.**

**Setting the operating mode**

With the selector switch for drilling/hammer drilling **7**, the operating mode of the machine is selected.

**Note:** Change the operating mode only when the machine is switched off! Otherwise, the machine can be damaged.

- To change the operating mode, turn the selector switch for “drilling/hammer drilling” **7** to the requested position.

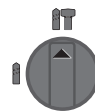

Position for **hammer drilling** in concrete or stone



Position for **drilling** without impact in wood, metal, ceramic and plastic as well as for screwdriving

**Reversing the rotational direction (GBH 2-18 RE) (see figure I)**

The rotational direction switch **6** is used to reverse the rotational direction of the machine. However, this is not possible with the On/Off switch **5** actuated.

## 16 | English

➤ **Right rotation:** Push the rotational direction switch **6** rightward to the stop.

➤ **Left rotation:** Push the rotational direction switch **6** leftward to the stop.

For hammer drilling and drilling, always set the direction of rotation to right rotation.

#### Switching On and Off

- To **start** the machine, press the On/Off switch **5**.
- To **lock** the On/Off switch, keep it pressed and additionally push the lock-on button **4**.
- To **switch off** the machine, release the On/Off switch **5**. When the On/Off switch **5** is locked, press it first and then release it.

#### Setting the Speed/Impact Rate

The speed/impact rate of the switched on power tool can be variably adjusted, depending on how far the On/Off switch **5** is pressed.

Light pressure on the On/Off switch **5** results in low speed/impact rate. Further pressure on the switch increases the speed/impact rate.

#### Overload Clutch

- ▶ **If the tool insert becomes caught or jammed, the drive to the drill spindle is interrupted. Because of the forces that occur, always hold the power tool firmly with both hands and provide for a secure stance.**
- ▶ **If the power tool jams, switch the machine off and loosen the tool insert. When switching the machine on with the drilling tool jammed, high reaction torques can occur.**

#### Working Advice

- ▶ **Before any work on the machine itself, pull the mains plug.**

#### Inserting Screwdriver Bits (see figure J)

- ▶ **Apply the power tool to the screw/nut only when it is switched off.** Rotating tool inserts can slip off.
- ▶ **Hold the tool by the insulated gripping surfaces when performing operations where the application tool or the screw could contact hidden wiring or its own power cord.** Contact with a "live" wire will also make exposed metal parts of the power tool "live" and shock the operator.

To work with screwdriver bits, a universal bit holder **22** with SDS-plus shank (accessory) is required.

- Clean the shank end of the adapter shank and apply a light coat of grease.
- Insert the universal bit holder with a turning motion into the tool holder until it automatically locks.
- Check the locking effect by pulling the universal bit holder.
- Insert a screwdriver bit into the universal bit holder. Use only screwdriver bits that match the screw head.
- To remove the universal bit holder, pull the locking sleeve **3** toward the rear and remove the universal bit holder **22** out of the tool holder.

## Maintenance and Service

### Maintenance and Cleaning

- ▶ **Before any work on the machine itself, pull the mains plug.**
- ▶ **For safe and proper working, always keep the machine and ventilation slots clean.**
- ▶ **A damaged dust protection cap should be changed immediately. We recommend having this carried out by an after-sales service.**
- Clean the tool holder **1** each time after using.

If the replacement of the supply cord is necessary, this has to be done by Bosch or an authorized Bosch service agent in order to avoid a safety hazard.

### After-sales Service and Application Service

Our after-sales service responds to your questions concerning maintenance and repair of your product as well as spare parts. Exploded views and information on spare parts can also be found under:

**www.bosch-pt.com**

Bosch's application service team will gladly answer questions concerning our products and their accessories.

In all correspondence and spare parts orders, please always include the 10-digit article number given on the nameplate of the product.

#### People's Republic of China

##### China Mainland

Bosch Power Tools (China) Co., Ltd.  
567, Bin Kang Road  
Bin Jiang District 310052  
Hangzhou, P. R. China  
Service Hotline: 4008268484  
Fax: (0571) 87774502  
E-Mail: contact.ptcn@cn.bosch.com  
www.bosch-pt.com.cn

#### HK and Macau Special Administrative Regions

Robert Bosch Hong Kong Co. Ltd.  
21st Floor, 625 King's Road  
North Point, Hong Kong  
Customer Service Hotline: +852 2101 0235  
Fax: +852 2590 9762  
E-Mail: info@hk.bosch.com  
www.bosch-pt.com.hk

#### Indonesia

PT Robert Bosch  
Palma Tower 10<sup>th</sup> Floor  
Jl. RA Kartini II-S Kaveling 6 Sek II  
Pondok Pinang, Kebayoran Lama  
Jakarta Selatan 12310  
Indonesia  
Tel.: (021) 3005 5800  
Fax: (021) 3005 5801  
E-Mail: boschpowertools@id.bosch.com  
www.bosch-pt.co.id



**Philippines**

Robert Bosch, Inc.  
28th Floor Fort Legend Towers,  
3rd Avenue corner 31st Street,  
Fort Bonifacio Global City,  
1634 Taguig City, Philippines  
Tel.: (02) 8703871  
Fax: (02) 8703870  
matheus.contiero@ph.bosch.com  
www.bosch-pt.com.ph

Bosch Service Center:  
9725-27 Kamagong Street  
San Antonio Village  
Makati City, Philippines  
Tel.: (02) 8999091  
Fax: (02) 8976432  
E-Mail: rosalie.dagdagan@ph.bosch.com

**Malaysia**

Robert Bosch Sdn. Bhd.  
No. 8A, Jalan 13/6  
G.P.O. Box 10818  
46200 Petaling Jaya  
Selangor, Malaysia  
Tel.: (03) 79663194  
Fax: (03) 79583838  
E-Mail: cheehoe.on@my.bosch.com  
Toll-Free: 1800 880188  
www.bosch-pt.com.my

**Thailand**

Robert Bosch Ltd.  
Liberty Square Building  
No. 287, 11 Floor  
Silom Road, Bangrak  
Bangkok 10500  
Tel.: 02 6393111  
Fax: 02 2384783  
Robert Bosch Ltd., P. O. Box 2054  
Bangkok 10501, Thailand  
www.bosch.co.th

Bosch Service – Training Centre  
La Salle Tower Ground Floor Unit No.2  
10/11 La Salle Moo 16  
Srinakharin Road  
Bangkaew, Bang Plee  
Samutprakarn 10540  
Thailand  
Tel.: 02 7587555  
Fax: 02 7587525

**Singapore**

Powerwell Service Centre Ptd Ltd  
65 Ubi Crescent, #06-03 Hola Centre  
Singapore 408559  
Tel.: 6746 9770/71  
Fax: 6746 9760  
E-Mail: powerwellsc@gmail.com  
Toll-Free: 1800 3338333  
www.bosch-pt.com.sg

**Vietnam**

Robert Bosch Vietnam Co. Ltd  
13th Floor , 194 Golden Building  
473 Dien Bien Phu Street  
Ward 25, Binh Thanh District  
84 Ho Chi Minh City  
Vietnam  
Tel.: (08) 6258 3690  
Fax: (08) 6258 3692  
Hotline: (08) 6250 8555  
E-Mail: tuvankhachhang-pt@vn.bosch.com  
www.bosch-pt.com.vn  
www.baohanhbosch-pt.com.vn

**Australia, New Zealand and Pacific Islands**

Robert Bosch Australia Pty. Ltd.  
Power Tools  
Locked Bag 66  
Clayton South VIC 3169  
Customer Contact Center  
Inside Australia:  
Phone: (01300) 307044  
Fax: (01300) 307045  
Inside New Zealand:  
Phone: (0800) 543353  
Fax: (0800) 428570  
Outside AU and NZ:  
Phone: +61 3 95415555  
www.bosch-pt.com.au  
www.bosch-pt.co.nz

**Egypt**

Unimar  
20 Markaz kadmat  
El tagmoa EL Aoul – New Cairo  
Tel: +2 02 224 76091 - 95 / + 2 02 224 78072 - 73  
Fax: +2 02 224 78075  
E-Mail: adelzaki@unimaregypt.com

**Ethiopia**

Forever plc  
Kebele 2,754, BP 4806,  
Addis Ababa , Ethiopia  
Tel: +251 111 560 600, +251 111 560 600  
E-Mail: foreverplc@ethionet.et

**Nigeria**

C. Woermann Ltd.  
P.O. Box 318  
6, Badejo Kalesanwo Street  
Matori Industrial Estate  
Lagos, Nigeria  
Tel: +234 17 736 498, +234 17 730 904  
E-Mail: d.kornemann@woermann-nigeria.com

**Republic of South Africa**

**Customer service**  
Hotline: (011) 6519600

18 | English

**Gauteng – BSC Service Centre**

35 Roper Street, New Centre  
Johannesburg  
Tel.: (011) 4939375  
Fax: (011) 4930126  
E-Mail: bsctools@icon.co.za

**KZN – BSC Service Centre**

Unit E, Almar Centre  
143 Crompton Street  
Pinetown  
Tel.: (031) 7012120  
Fax: (031) 7012446  
E-Mail: bsc.dur@za.bosch.com

**Western Cape – BSC Service Centre**

Democracy Way, Prosperity Park  
Milnerton  
Tel.: (021) 5512577  
Fax: (021) 5513223  
E-Mail: bsc@zsd.co.za

**Bosch Headquarters**

Midrand, Gauteng  
Tel.: (011) 6519600  
Fax: (011) 6519880  
E-Mail: rbsa-hq.pts@za.bosch.com

**Disposal**

The machine, accessories and packaging should be sorted for environmental-friendly recycling.

Do not dispose of power tools into household waste!

**Subject to change without notice.**